



SPECTERA

SEK (UHF) | SEK (1G4)



SPECTERA SEK (UHF)

SPECTERA SEK (1G4)

Each bidirectional Spectera SEK bodypack manages both an IEM/IFB and a mic/line stream simultaneously. Plus, they allow for full remote control and monitoring, via identical RF connection, of IEM volume, audio level and settings, RF health, battery status, and more via LinkDesk software and Spectera WebUI. Variants include UHF (470 – 608 MHz and 630 – 698 MHz) or 1G4 (1350 – 1400 MHz and 1435 – 1525 MHz).

FEATURES

- Bidirectional bodypack manages both digital IEM/IFB and mic/line signals simultaneously
- Bidirectional audio signals and control data in identical RF carrier of all mobile devices
- Available variants: UHF (470 – 608 MHz and 630 – 698 MHz) or 1G4 (1350 – 1400 MHz and 1435 – 1525 MHz)
- Full remote control and monitoring of SEK bodypack: IEM volume, mic/line gain, RF health, battery status, and more
- Impedance-matching high-power headphone amplifier
- Continuous interference management
- Endless encoder with push button
- 3-pin mic/line input and IEM/IFB 3.5 mm headphone connector
- LED meter, status LED and persistent display for “always on” information — name visible on screen even when batteries are removed
- Up to 7 hours of operating time depending on the selected Audio Link mode and settings with BA 70 rechargeable lithium-ion battery (sold separately)
- Encrypted RF connection between the Base Station and bodypack
- Secure transmission of confidential content using AES 256 encryption
- Versatile charging options also available: L 70 USB, LM 6070 Module for L 6000 full rack charging station and charging contacts for in-device charging with CHG 70N-C
- Compatible with a wide range of Sennheiser lavalier and headset microphones with 3-pin locking connector and in-ear monitors with 3.5 mm connector
- Rugged metal housing

DELIVERY INCLUDES

- Spectera SEK UHF or 1G4
- Spectera SEK Belt Clip
- Spectera SEK Antenna UHF or 1G4
- 3-pin Protective Cap MIC/LINE
- Pouch
- Quick guide
- Safety guide
- Manufacturer declaration sheet

PRODUCT VARIANTS

SPECTERA SEK (UHF)

470 – 608 MHz and 630 – 698 MHz

Art. no. 509164

SPECTERA SEK (1G4)

1350 – 1400 MHz and 1435 – 1525 MHz

Art. no. 509163



SPECTERA

SEK (UHF) | SEK (1G4)

ACCESSORIES

SPECTERA SEK Antenna (UHF)	Exchangeable flexible antenna for the frequency ranges UHF (470 - 698 MHz)	Art. no. 700066
SPECTERA SEK Antenna (1G4)	Exchangeable flexible antenna for the frequency ranges 1G4 (1350 - 1525 MHz)	Art. no. 700067
3pin protective cap MIC/LINE	Exchangeable protective cap for Mic/Line 3-pin connector	Art. no. 700072
SPECTERA SEK Belt Clip	Exchangeable vertical clip	Art. no. 700071
COM Button	Command adapter	Art. no. 701014
BA 70	Rechargeable battery pack	Art. no. 508860
L 70 USB	USB charger with dual slots for BA 70	Art. no. 508861
CHG 70N-C	Network enabled charger	Art. no. 700332
L 6000	Charging station with exchangeable charging modules (LM 6070)	Art. no. 507300



SPECTERA

SEK (UHF) | SEK (1G4)

SPECIFICATIONS

System

Transmission scheme	Multicarrier, TDMA, TDD
RF channel	Bandwidth: 6 or 8 MHz countrywise limited Mobiles devices: up to 128 per RF channel Audio links: up to 128 per RF channel
Radio frequency range	UHF: 470 - 608 MHz, 630 - 698 MHz 1G4: 1350 - 1400 MHz, 1435 - 1525 MHz countrywise limited
Audio frequency response	20 Hz to 20,000 Hz (± 1 dB) (Audio link modes with audio codecs SeDAC and PCM only)
Encryption	AES 256 CTR Mode exp. >10k years

Audio link modes

MIC/LINE	Mono	Max links per RF carrier	Utilized % of RF carrier	Audio codec	Latency	Range
Raw Low Latency	Mono	8	12.50 %	PCM	1.0 ms	Reduced
Raw	Mono	16	6.25 %	PCM	1.6 ms	Reduced
Live Low Latency	Mono	8	12.50 %	SeDAC	1.0 ms	Extended
Live	Mono	16	6.25 %	SeDAC	1.6 ms	Extended
Live Link Density	Mono	32	3.13 %	SeDAC	2.7 ms	Standard
Max Range	Mono	16	6.25 %	OPUS	9.9 ms	Maximum
Max Link density	Mono	128*	0.78 %	OPUS	15.2 ms	Reduced
IEM/IFB	Mono/ Stereo	Max links per RF carrier	Utilized % of RF carrier	Audio codec	Latency	Range
Live	Mono	16	6.25 %	SeDAC	1.6 ms	Extended
Live Link Density	Mono	32	3.13 %	SeDAC	2.7 ms	Standard
Max Range	Mono	16	6.25 %	OPUS	9.9 ms	Maximum
Max Link density	Mono	128*	0.78 %	OPUS	15.2 ms	Reduced
Live Ultra Low Latency	Stereo	4 (8 ch)	25 %	SeDAC	0.7 ms	Extended
Live Low Latency	Stereo	8 (16 ch)	12.50 %	SeDAC	1.1 ms	Extended
Live	Stereo	16 (32 ch)	6.25 %	SeDAC	1.6 ms	Standard
Live Link Density	Stereo	32 (64 ch)**	3.13 %	SeDAC	2.7 ms	Reduced

* Base Stations have 32 audio outputs, for 128 links in a single RF channel, 4 Base Stations and firmware update with cascade port function are required (future release)

** Base Stations have 32 audio inputs, for 32 stereo links (64 ch) in a single RF channel, 2 Base Stations and firmware update with cascade port function are required (future release)



SPECTERA

SEK (UHF) | SEK (1G4)

SPECIFICATIONS

SPECTERA SEK (UHF) | SEK (1G4)

RF transmission power	up to 50 mW; countrywise limited
RF channels	1
Headphone output	3.5 mm TRS jack 2 × 300 mW RMS (32 Ω, -40 dB THD, 1 kHz)
Microphone / Instrument / Command input	3-pin audio socket
Power supply	BA 70 rechargeable battery pack
Battery operating time	up to 7 h (unidirectional microphone use) up to 6 h (unidirectional IEM use) up to 5 h (bidirectional use)
Dimensions	approx. 83.5 x 62 x 21 mm (3.39" x 2.44" x 0.83") (without antenna)
Weight	approx. 178 g (0.39 lbs) (with BA 70) approx. 144 g (0.32 lbs) (without BA 70)
Temperature	Operation: -10 °C to +50 °C (14 °F to 122 °F) Storage: -25 °C to +70 °C (-13 °F to 158 °F)
Relative humidity	25 % to 95 % (non-condensing)



SPECTERA

SEK (UHF) | SEK (1G4)

DIMENSIONS

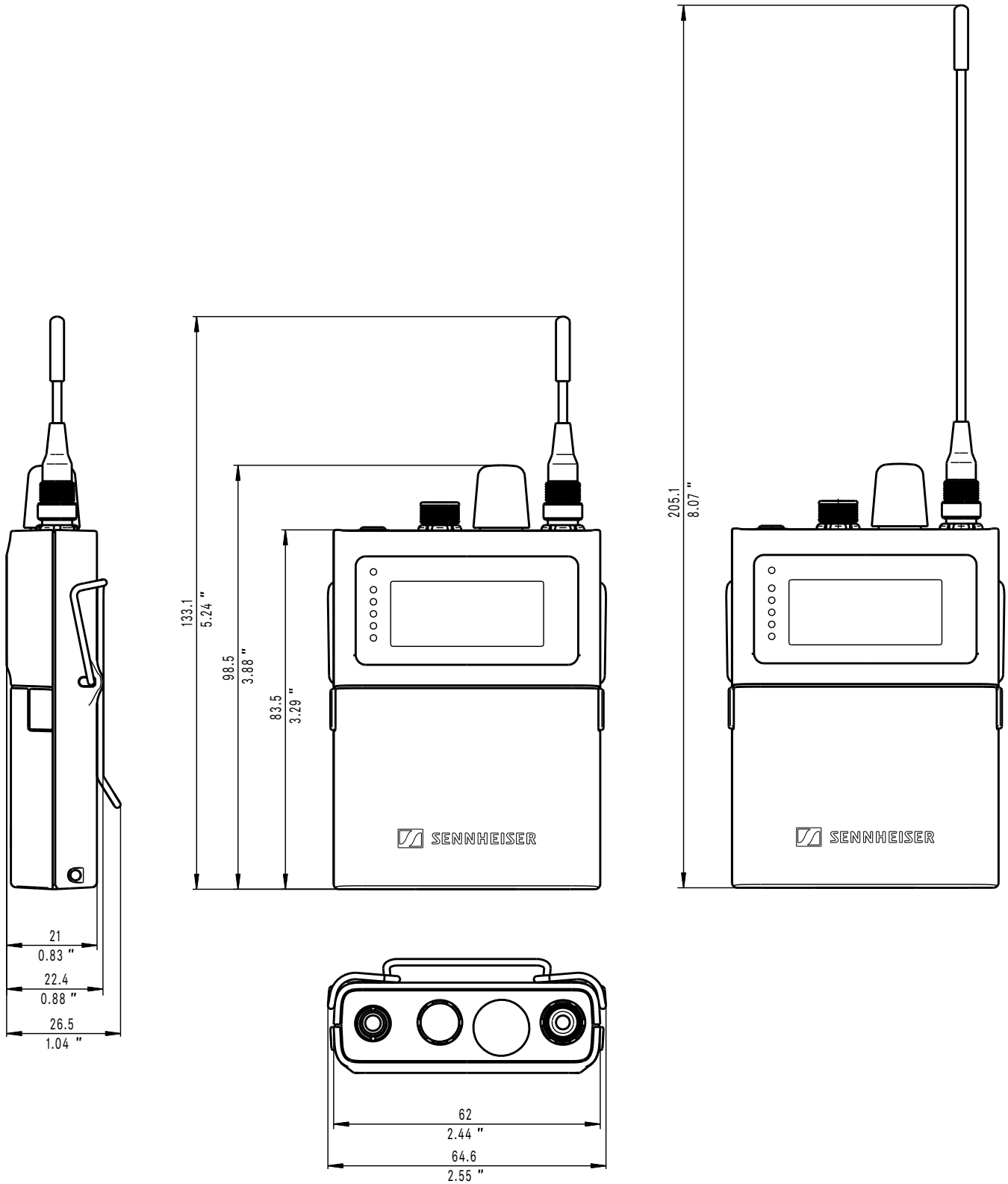



SPECTERA

SEK (UHF) | SEK (1G4)

ARCHITECT'S SPECIFICATION

Sennheiser Spectera/ System description / Intro text

Digital bidirectional (uplink/ downlink) multicarrier/ TDMA/ TDD wireless system for simultaneous transmission of up to 32 audio input and output channels. The system shall use digital broadband transmission technology for this purpose. It shall be based on wireless multichannel audio systems technology (WMAS) and its combination of modulation and multiplexing methods.

Data and audio transmission, as well as remote control and monitoring data, shall be carried out via a single RF carrier, avoiding the 2.4 ISM band.

The system shall operate in the TV UHF band or the 1.4/1.5 GHz band. It shall operate with an RF channel bandwidth of 6 or 8 MHz and shall pair up to 128 mobile devices per RF channel.

It shall provide a switching bandwidth of 194 MHz (UHF) or 128 MHz (1.4 GHz), which shall be identical for all RF components in the system; the base station shall be frequency-independent and both frequency bands shall be operated simultaneously by a single base station.

The system shall consist of the following components:

- Base Station in 19"/1U format (shall allow up to two independent wideband RF carriers in UHF or 1G4 band). The base station shall process only digital audio signals without any analog components (compander, RF emphasis, etc.).
- Bodypacks for simultaneous use as both in-ear monitoring receiver and transmitter for microphone/line audio signals.
- Digital bidirectional antenna with integrated RF components (up to four pieces shall be used simultaneously).
- Proprietary desktop application for comprehensive system management.
- Handheld microphone (in development).

The system can be operated with only one antenna. Up to four antennas can be connected to a single base station and operated in multi-zone mode with improved antenna coverage and optimized signal-to-noise ratio. The connection between the base station and antennas shall be a digital 1 Gb/s connection via a CAT5e (or higher) cable with a maximum length of 100 m.

For all system components, data and audio shall be transmitted via a single RF carrier. The system shall support up to 128 audio channels per RF channel, with each channel individually configurable (audio codec, latency, operating range).

The audio frequency response of the system shall be 20 Hz to 20,000 Hz, the system latency shall be min. 0.7 ms for stereo audio links/ 1 ms for mono audio links. The system shall offer 11 audio link/transmission modes, including a mode for linear PCM format. Each channel can be operated in a different mode; Modes can be changed at any time and without rebooting. The internal audio processing shall be done in 32-bit float format.

100 – 240 V power supply units, Dante and optional MAD1 connectors shall be redundant; a total of up to four antennas can be operated simultaneously.

The system shall have AES 256 end-to-end encryption.

The system shall be remotely controlled and monitored via Windows, macOS native software and a WebUI.

The system shall comply with all relevant international standards and regulations for wireless audio transmission. It shall be certified for use in a wide variety of regions (including the EU, USA and Canada).



SPECTERA

SEK (UHF) | SEK (1G4)

Digital bidirectional bodypack (Sennheiser Spectera SEK UHF)

Digital bidirectional bodypack transceiver for wireless transmission of digital audio and control data. The transceiver shall simultaneously transmit both stereo/mono IEM/IFB and mono mic/line signals via a single antenna via a 6 or 8 MHz RF channel to match the wireless system described in the system description.

The bodypack shall provide continuous interference measurement for the RF channel without interrupting the audio signals. Interference or deterioration in connection quality shall be indicated via the proprietary software or WebUI. In addition, permanent full remote control and monitoring of IEM volume and balance, audio level, audio settings, battery status, and RF channel quality parameters shall be provided via the software.

The transceiver shall have a display that shows information even when the batteries are removed. In addition, the transceiver shall offer a power saving mode that activates automatically when it is out of range of its coupled transceiver antenna for a certain period of time.

The antenna of the bodypack shall be replaceable, the battery shall be charged in a separate 19" charging station or via the charging contacts on the SEK in a charging cradle.

The AD/DA converters of all connected bodypacks shall be clocked by a mutual word clock signal. The synchronized word clock for all audio signals shall also allow for immersive on-air 3D audio recording and playback.

The headphone volume shall be adjusted in 0.5 dB steps.

Technical requirements

Specifications:

- RF Channels: 1 (6 or 8 MHz)
- Transmission scheme: Multicarrier, TDMA, TDD
- Frequency range: UHF 470 – 608 MHz, 630 – 698 MHz
- Audio connections/mobile devices: up to 128 per RF channel
- RF transmitting power: max. 50 mW
- Encryption: AES 256
- Audio frequency response: 20 Hz – 20,000 Hz (± 1 dB)
- Hi-Pass Filter: off/ 30/ 60/ 80/ 100/ 120 Hz
- Mic gain: -6 to 42 dB, in 1 dB steps
- Mic level: max. 7 Vpp @ 1 kHz
- Line level: max. 9 Vpp @ 1 kHz
- Battery operating time: up to 7 h (unidirectional)/ 5 h (bidirectional)

Connections, Displays & Controls:

- 1 x 3.5 mm headphone output; 2 x 400 mW RMS (16 Ω , @ 1 kHz)
- 1 x 3-Pin Connector (female) Mic/ Line In
- 1 x Antenna Connector
- 1 x Endless Encoder / Switch
- 1 x 5 Segment LED Meter
- 1 x Status LED
- 1 x Display
- 1 x Power Switch (Covered)

Physical Properties:

- Dimensions: 83.5 x 62 x 21 mm (without antenna)
- Weight: approx. 144 g/ 178 g (without/ with battery)
- Material: Metal
- Operating temperature: approx. -10 °C to +50 °C
- Relative humidity: 25% - 95%
- Power supply: Li-ion battery

Bodypack shall include antenna and belt clip.



SPECTERA

SEK (UHF) | SEK (1G4)

Digital bidirectional bodypack (Sennheiser Spectera SEK 1G4)

Digital bidirectional bodypack transceiver for wireless transmission of digital audio and control data. The transceiver shall simultaneously transmit both stereo/mono IEM/IFB and mono mic/line signals via a single antenna via a 6 or 8 MHz RF channel to match the wireless system described in the system description.

The bodypack shall provide continuous interference measurement for the RF channel without interrupting the audio signals. Interference or deterioration in connection quality shall be indicated via the proprietary software or WebUI. In addition, permanent full remote control and monitoring of IEM volume and balance, audio level, audio settings, battery status, and RF channel quality parameters shall be provided via the software.

The transceiver shall have a display that shows information even when the batteries are removed. In addition, the transceiver shall offer a power saving mode that activates automatically when it is out of range of its coupled transceiver antenna for a certain period of time.

The antenna of the bodypack shall be replaceable, the battery shall be charged in a separate 19" charging station or via the charging contacts on the SEK in a charging cradle.

The AD/DA converters of all connected bodypacks shall be clocked by a mutual word clock signal. The synchronized word clock for all audio signals shall also allow for immersive on-air 3D audio recording and playback.

The headphone volume shall be adjusted in 0.5 dB steps.

Technical requirements

Specifications:

- RF Channels: 1 (6 or 8 MHz)
- Transmission scheme: Multicarrier, TDMA, TDD
- Frequency range: 1G4 1350 – 1400 MHz, 1435 – 1525 MHz
- Audio connections/mobile devices: up to 128 per RF channel
- RF transmitting power: max. 50 mW
- Encryption: AES 256
- Audio frequency response: 20 Hz – 20,000 Hz (± 1 dB)
- Hi-Pass Filter: off/ 30/ 60/ 80/ 100/ 120 Hz
- Mic gain: -6 to 42 dB, in 1 dB steps
- Mic level: max. 7 Vpp @ 1 kHz
- Line level: max. 9 Vpp @ 1 kHz
- Battery operating time: up to 7 h (unidirectional)/ 5 h (bidirectional)

Connections, Displays & Controls:

- 1 x 3.5 mm headphone output; 2 x 400 mW RMS (16 Ω , @ 1 kHz)
- 1 x 3-Pin Connector (female) Mic/ Line In
- 1 x Antenna Connector
- 1 x Endless Encoder / Switch
- 1 x 5 Segment LED Meter
- 1 x Status LED
- 1 x Display
- 1 x Power Switch (Covered)

Physical Properties:

- Dimensions: 83.5 x 62 x 21 mm (without antenna)
- Weight: approx. 144 g/ 178 g (without/ with battery)
- Material: Metal
- Operating temperature: approx. -10 °C to +50 °C
- Relative humidity: 25% - 95%
- Power supply: Li-ion battery

Bodypack shall include antenna and belt clip.